

KBWT INSTALLATION INSTRUCTIONS

SAFETY WARNING! — PLEASE READ CAREFULLY

This product should be installed and serviced by a qualified technician, electrician or electrical maintenance person familiar with its operation and the hazards involved. Proper installation, which includes wiring, mounting in proper enclosure, fusing or other overcurrent protection and grounding, can reduce the chance of electric shocks, fires or explosion in this product or products used with this product, such as electric motors, switches, coils, solenoids or relays. Eye protection must be worn and insulated adjustment tools must be used when working with control under power. This product is constructed of materials (plastics, metals, carbon, silicon, etc.) which may be a potential hazard. Proper shielding, grounding and filtering of this product can reduce the emission of radio frequency interference (RFI) which may adversely affect sensitive electronic equipment. If information is required on this product, contact our factory. It is the responsibility of the equipment manufacturer and individual installer to supply this safety warning to the ultimate user of this product. (SW effective 11/92)

This control may contain electronic Start/Stop and Enable circuits that can be used to start and stop the control. However, these circuits are never to be used as safety disconnects since they are not fail-safe. Use only the AC line for this purpose.

The input circuits of this control (tachometer, start/stop, inhibit, enable) are not isolated from AC line. **Be sure to follow all instructions carefully. Fire and/or electrocution can result due to improper use of this product.**

 This product complies with all CE directives pertinent at the time of manufacture. Contact factory for detailed installation instructions and Declaration of Conformity. Installation of a CE approved RFI filter (KBRF-200A, KB P/N 9945C or equivalent) is required. Additional shielded motor cable and/or AC line cables may be required along with a signal isolator (KBSI-240D, KB P/N 9431 or equivalent).

MOUNTING

The KBWT should be mounted on a flat surface and located in an area where it will not be exposed to contaminants such as water, metal chips, solvents or excessive vibration. When mounting in an enclosure, the air space should be large enough to provide adequate ventilation. The maximum allowable ambient temperature at full rating is 45°C/113°F. Consult factory if more information is required.

MECHANICAL SPECIFICATIONS – inches/[mm]

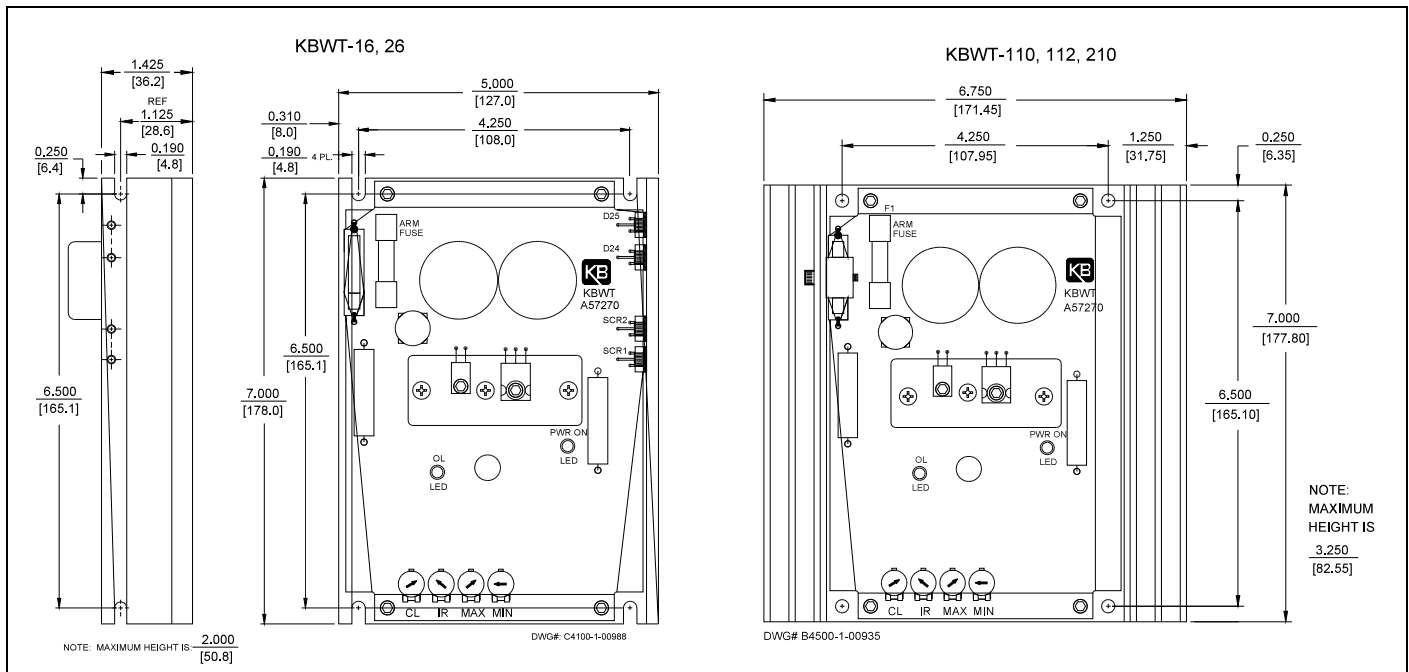

WIRING – Warning! Read Safety Warning before attempting to use this control.

AC Line – Connect AC line to terminals L1 and L2. It is recommended that a line fuse or circuit breaker be installed.

Motor Armature – Connect motor armature to terminals A+ and A-. Be sure motor voltage corresponds to control output voltage range. It is recommended that a fuse be installed in series with the armature; choose a fuse rating 1.5 times the full load motor rating.

Main Potentiometer – The control can be operated from a remote potentiometer, or from an *isolated* analog voltage for voltage following.

Remote Potentiometer – Connect remote potentiometer wires to terminals P1, P2 and P3, so that the "high" side of the potentiometer connects to P3, the "wiper" to P2 and the "low" side to P1.



"The Right Control
for Your Application"

KB ELECTRONICS, INC.
12095 NW 39th Street, Coral Springs, FL 33065-2516 • (954) 346-4900 • Fax (954) 346-3377
Outside Florida Call **TOLL FREE** (800) 221-6570 • **E-mail** – info@kbelectronics.com
www.kbelectronics.com

This control may contain a potentiometer safety reset circuit. When power is first applied, you must rotate the main speed potentiometer fully CCW or adjust your analog input signal to 0 VDC, then increase setting to desired speed. To disable this feature, you can remove the D20 Diode from the circuit board.

Warning! This control has been Hi-Pot tested at the factory. If you choose to perform another Hi-Pot test on the control, there is a risk that the control can be damaged. Please consult factory for more information.

Analog Input – An isolated 0-5 VDC analog voltage can also be used to drive the control. Note: If an isolated signal voltage is not available, an optional signal isolator can be installed (Model KBSI-240D, P/N 9431). Connect the isolated input voltage to terminal P2 (positive) and P1 (negative).

Microprocessor Input – An isolated PWM signal from a microprocessor can be used to operate the control. The output frequency should be 200 Hz or greater and should be derived from an optocoupler with a transistor or operational amplifier signal output.

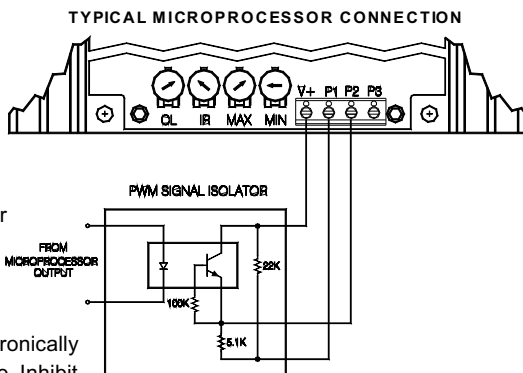

INHIBIT

The control can be electronically stopped and started with the Inhibit circuit. To "Stop" the control, terminals I1 & I2 must be shorted via a contact. The control can be restarted by opening the contact. **Note: The Inhibit should not be used as a safety disconnect. Use only the AC line for that purpose. The Inhibit Circuit is not isolated. Do not earth ground inhibit leads.**

OPERATION – **WARNING! Read Safety Warning before attempting to operate the control or severe injury or electrocution can result.**

After the control has been set up properly and the wiring has been completed, the start-up procedure can begin. If AC power has been properly connected to the control, the "ON" LED indicator will illuminate. Before starting, be sure the main potentiometer is in the minimum position. To start the control, the potentiometer knob should be rotated clockwise; the motor should begin to rotate. **Note: If the motor rotates in the incorrect direction, it will be necessary to disconnect the main AC power and reverse the armature wires.**

CONNECTION DIAGRAM

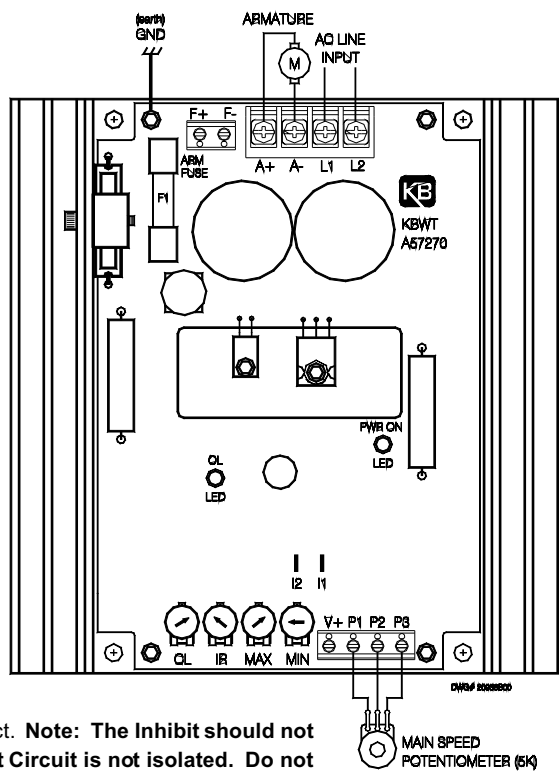

ELECTRICAL RATINGS

Model No.	KB Part No.	AC Line Voltage (VAC) -10%,+15% (50/60 Hz)	Maximum AC Line Current (Amps RMS)	MAXIMUM DC OUTPUT CURRENT					Maximum Motor Horsepower (KW)		(Optional) Armature Fuse Rating (Amps)
				CONTINUOUS DUTY RATING				Current Limit Max. Setting (Amps DC)	Continuous Duty	Intermittent Duty (1 minute)	
				Amps DC	@ Output Voltage	Amps DC	@ Output Voltage				
KBWT-16	8614	115	10.0	6.0	90	6.0	130	10.0	0.75 (0.5)	1.5 (1.1)	15
KBWT-26	8615	230	10.0	6.0	180	6.0	260	10.0	1.5 (1.1)	3.0 (2.0)	15
KBWT-110	8603	115	15.0	10.0	90	8.5	130	17.0	1.2 (0.9)	2.0 (1.5)	20
KBWT-112	8612	115	18.0	12.0	90	10.5	130	25.0	1.5 (1.1)	2.5 (1.9)	25
KBWT-210	8610	230	15.0	10.0	180	8.5	260	17.0	2.2 (1.7)	4.0 (3.0)	20

TRIMPOT ADJUSTMENTS

The control contains trimpots which have been factory adjusted for most applications. The connection diagram illustrates the location of the trimpots and their approximate adjustment positions. Some applications may require readjustment of the trimpots in order to tailor the control to exact requirements.

FUNCTION INDICATOR LAMPS

The control contains two LED indicator lamps that reflect operational status.

- A. Power On Indicator (PWR ON)** – This lamp will glow GREEN when the AC line is connected to the control.
- B. Overload Indicator (OL)** – When the motor is loaded to the current limit (CL) setpoint (CL is established by the setting of the CL trimpot), this lamp will glow RED. If the control is allowed to stay in CL and then "times out" in Timed Current Limit, the CL LED will remain illuminated, until the control is restarted with the On/Off or Inhibit Switch. If the OL LED remains illuminated during control operation, a fault condition may exist.



KB ELECTRONICS, INC.
 12095 NW 39th Street, Coral Springs, FL 33065 • (954) 346-4900 • Fax (954) 346-3377
 Outside Florida Call TOLL FREE (800) 221-6570 • E-mail – info@kbelectronics.com
 www.kbelectronics.com